

CHILLED CEILING DATA SHEET



Dia.1

DESIGN & MATERIALS OF CONSTRUCTION

Hose: EPDM Rubber **Braid:** 304 Stainless Steel **Ferrule:** 303 Stainless Steel **Fittings:** CW617N or CW617N

DESCRIPTION

Hydrflex have been supplying flexible assemblies for chilled ceiling and beams for over 30 years and have an in depth understanding of the requirements and expectations of the industry. Hydrflex's range of quick release couplings ensure a problem free installation, reducing installation time by up to 40%; with continued ease for servicing and maintaining systems. With a 3:1 safety factor, a temperature range from -20°C to +85°C in a variety of bore sizes, Hydrflex's range of ceiling hoses are also tested and approved by BSRIA. Ceiling assemblies can be fitted with vapour sealed class O insulation to ensure maximum efficiency and fitted with end caps.

QUALITY & ASSOCIATED STANDARDS

Every assembly produced at Hydrflex undergoes a rigorous visual inspection, to ensure that only quality products are supplied. See the standards that Hydrflex meet:

- Manufactured under ISO 9001:2015 Procedures
- BSRIA BG4-2004

APPLICATIONS & ADVANTAGES

- Reduced Installation Time
- Flexible for installation in restricted areas and confined spaces
- Demountable without harm to pipework
- Available with Class O Insulation

HOSE DATA

Hose Part Number	ID	OD	WP @ 20°C	Min Bend	Minimum Assembly Cut Length	Coil Length	Ferrule
	MM	MM	Bar	MM	MM	M	
BX10	10	14	10	40	150	150	B15X16SS
BX13	13	17	10	60	150	100	B18.5X19.5SS

ASSEMBLY MEASUREMENTS

Diagram 2 displaying the overall length and cut length of a hose assembly

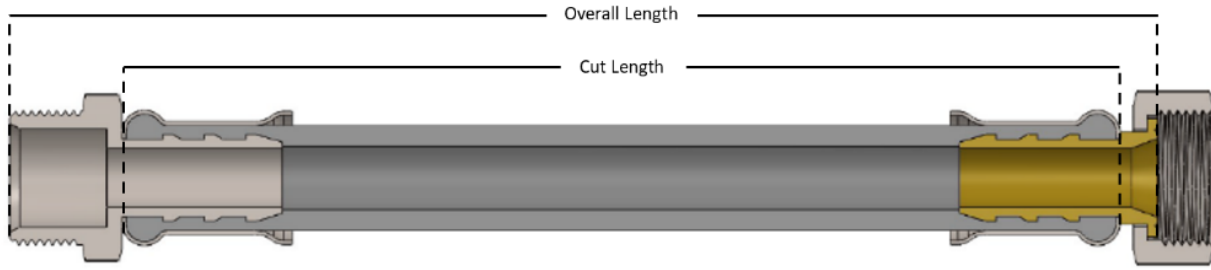

Dia.2

HOSE REDUCTION THROUGH FITTINGS

The arrow on drawing Diagram 3 denotes the 'R' measurement showing the 'Minimum Bore Through Fittings (mm)' which is reduced through the fitting tail, with a tolerance of +/- 0.2mm. The below measurements represent the minimum bore of each DN size; however, fittings will vary in bore size. For further information regarding this please contact our technical department.

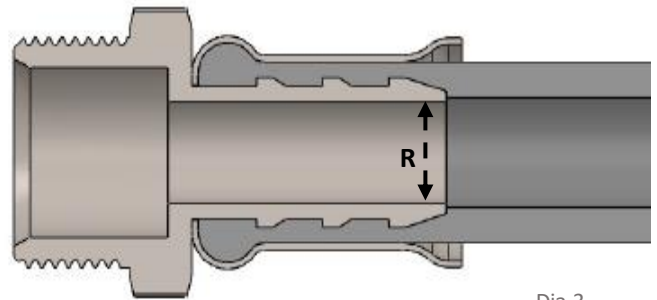

Dia.3

DN Size	Hose Bore (Inches)	Hose Bore (mm)	R = Minimum Bore Through Fittings (mm)
DN10	3/8"	10	6.7
DN13	1/2"	13	8.7

GEOMETRY AND MINIMUM BEND RADIUS

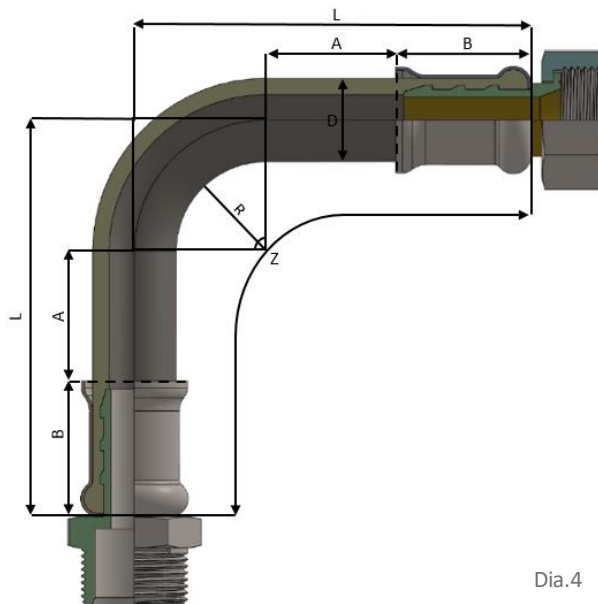

Dia.4

DN	D	R	A	B	L	Z/d90°	Z/180°	Z/d360°
DN10	14	40	40	20	107	183	246	258
DN13	18	60	60	22	151	258	352	540

WORKING AND THEORETICAL BURST PRESSURE

Working Pressure Bar (Tolerance +/- 1 Bar)										
		Temperature								
Part No.	Bore	20°C	30°C	40°C	50°C	60°C	70°C	80°C	90°C	100°C
BX10	DN10	20	20	20	20	18	18	17	17	16
BX13	DN13	20	20	20	20	15	15	14	14	13

Theoretical Minimum Burst Pressure (Bar)										
		Temperature								
Part No.	Bore	20°C	30°C	40°C	50°C	60°C	70°C	80°C	90°C	100°C
BX10	DN10	120	120	120	120	115	110	100	90	66
BX13	DN13	90	90	90	90	88	86	83	80	53

PRESSURE DROP

Schedule 1

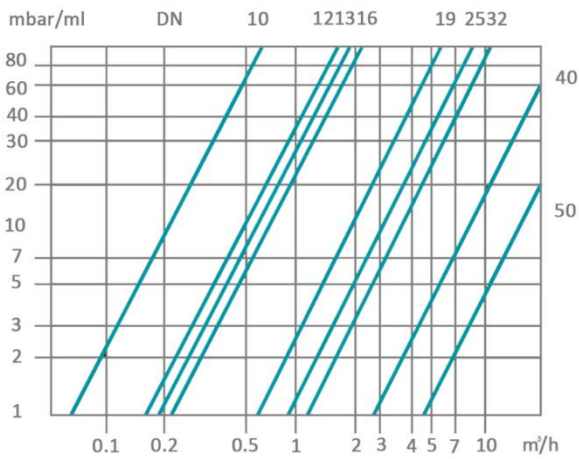

Schedule 2

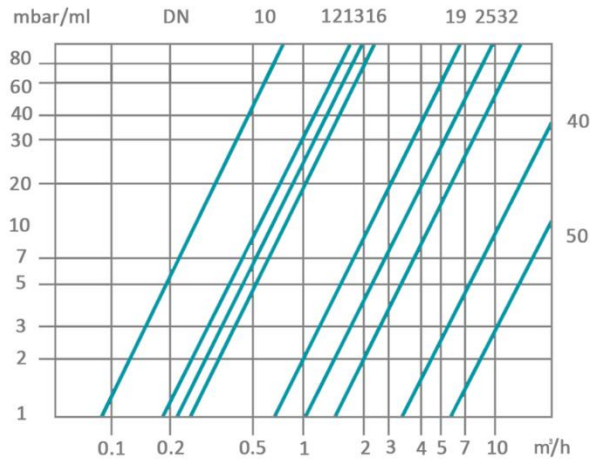

$$\text{Formula: } P_c = (T \times L) + R \text{ (in mbar)}$$

P_c = Pressure Drop in mbar

T = Pressure drop in mbar for one meter of hoses according to its flow capacity in M³/h (Schedule 1)

L = Hose Length in meters

R = Pressure drop in mbar caused by two fittings (male x female), same condition than 'T' (Schedule 2)

Flexible hose with one straight and one elbow fittings = $R \times 1.5$

Flexible hose with two elbow fittings = $R \times 3$

Example:

Flexible hose DN13 length 500mm 1 FP – MC, flow capacity 1000 l/h

$$P_c = (26 \text{ mbar/m} \times 0.5\text{m}) + 23 \text{ mbar} = 36 \text{ mbar}$$

Flexible hose DN25 length 800 1 FP – FPN, flow capacity 1500 l/h

$$P_c = (3\text{mbar/m} \times 0.8\text{m}) + (2.5 \text{ mbar} \times 1.5) = 9 \text{ mbar}$$

Note: 'T' value only valid for hoses installed straight. Installation with bend can cause pressure drop relative to decrease in bend radius.

FLEXIBLE HOSE INSTALLATION GUIDANCE NOTES

Prior to Installation

- Ensure that STAMPED is followed prior to fittings any flexible hose to ensure that the hose is fit for purpose.
 - Taking into consideration the maximum working parameters for operating and testing including; pressure, temperature, environment, medium. Making sure any additional factors are considered prior to installation and ensuring the hose assembly meets or exceeds the parameters of the application e.g. Consider using elbow fittings where tight bending is required.
- This information must not be assumed and is essential the correct due diligence has been undertaken.

Installation

- Before fitting ensure that there is no visible damage to the hose (if in doubt do not proceed to fitting the assembly).
- Ensure there is a slack on the hose with straight ends, as a tightly fitted hose may fail prematurely.
- Ensure that bend radii of the hose are not exceeded and there is sufficient length of hose to allow for a smooth curve. Do not bend hoses near to the crimped end fitting or twist and/or stretch hoses.
- Ensure where fittings with washers are used that the mating part is not sharp or uneven as this may damage the washer or prevent a secure seal.
- Ensure any hoses requiring insulation have sealed ends, failure to do so is likely to result in a build-up of moisture, resulting in corrosion and hose failure.
- Do make sure that the hose will not be rubbing on any edges once installed.
- Do use the correct type and size of tool when making the connections and ensure you do not over tighten fittings; over tightening may result in stress corrosion cracking (SCC).

N.B. Please be aware that external factors, included but not limited to heat, flux, solder, chemicals and condensation are likely to result in premature failure of a hose assembly.

Post Installation Check List

- Ensure circuits are flushed to clear any debris in accordance with current standards.
- Pressure test the circuit to ensure all connections are sound and secure in accordance with current standards.
- Hoses should be inspected at regular intervals for signs of corrosion or damage.

While this is an extensive list it is not exhaustive and should be used solely for guidance, if you require further information or clarification then please contact our technical support team. Failure to observe and comply with the above guidance notes may result in a hose failure and invalidate any warranty.

FURTHER INFORMATION

For any more information that you may require then please contact one of our team.

Tel: 0845 260 4334 Email: enquiries@hydraflex.co.uk